

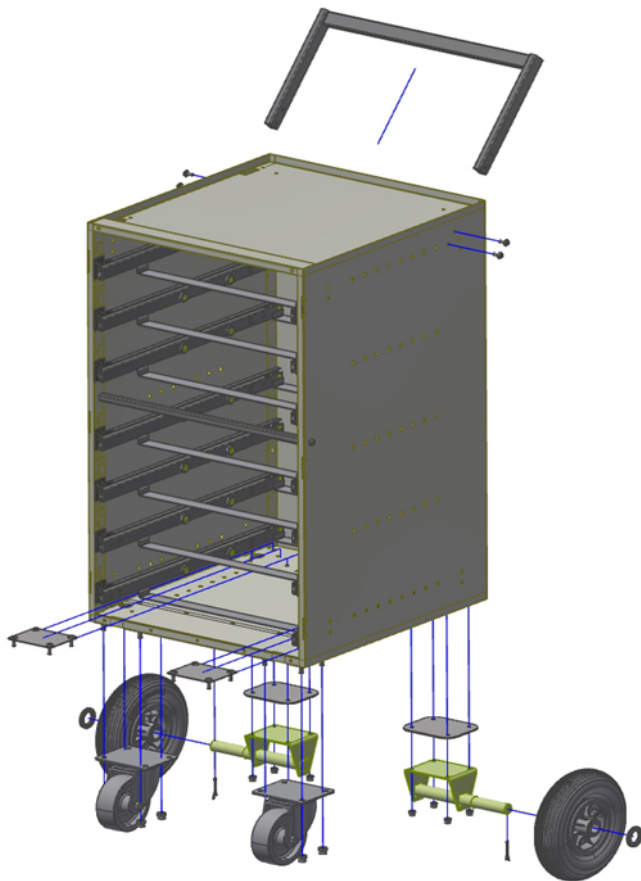

ROLA-CASE
ROLA-Shelf

RC7DC/PN & RCSK7PN/C
RC7DC/6D/PN &
RCSK7PN/6D/C
ASSEMBLY
INSTRUCTIONS

DESIGNED IN AUSTRALIA BY:
THOMAS MOLONEY PTY LTD.
PH 02 4340 1444 FAX 02 4340 1400
EMAIL enquiry@rolacase.com
www.rolacase.com



Supplied:

- 1x Handle
- 4x M6x12m Screws
- 2x Stud Plates
- 2x Packer Plates
- 2x Pneumatic wheel axles
- 2x Pneumatic wheels
- 2x Large Washers
- 2x Swivel castor wheels
- 16x M6 Nyloc nuts
- 16x M8 Nyloc nuts
- 2x Split pins
- 1x Double end spanner (10mm + 13mm)

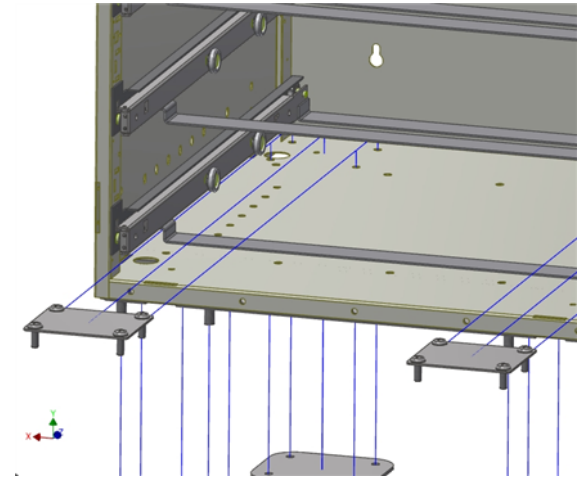

Procedure:

- 1/.** Insert the Handle into the 2 slots on top of the cabinet. (The handle angles towards the back of the cabinet). Secure the handle with the 4x M6 screws supplied.
- 2/.** Insert the 2 stud plates through the base of the cabinet from the inside where the holes are provided.
- 3/.** From underneath, place the packer plates on the studs (1 each side) then the pneumatic wheel axles. Secure to stud plates using the 16x M6 nuloc nuts provided.
- 4/.** Place the swivel castors on the M8 studs in the base of the cabinet and secure with the 16x M8 nyloc nuts provided.
- 5/.** Install the pneumatic wheels on the axles, then place washer on shaft and secure with the split pins supplied.